

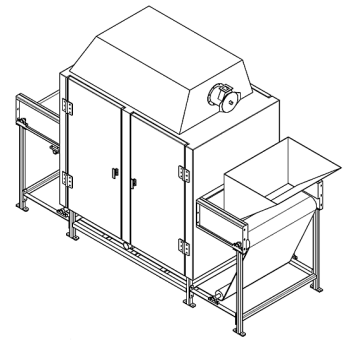

VESTA V1000-1H

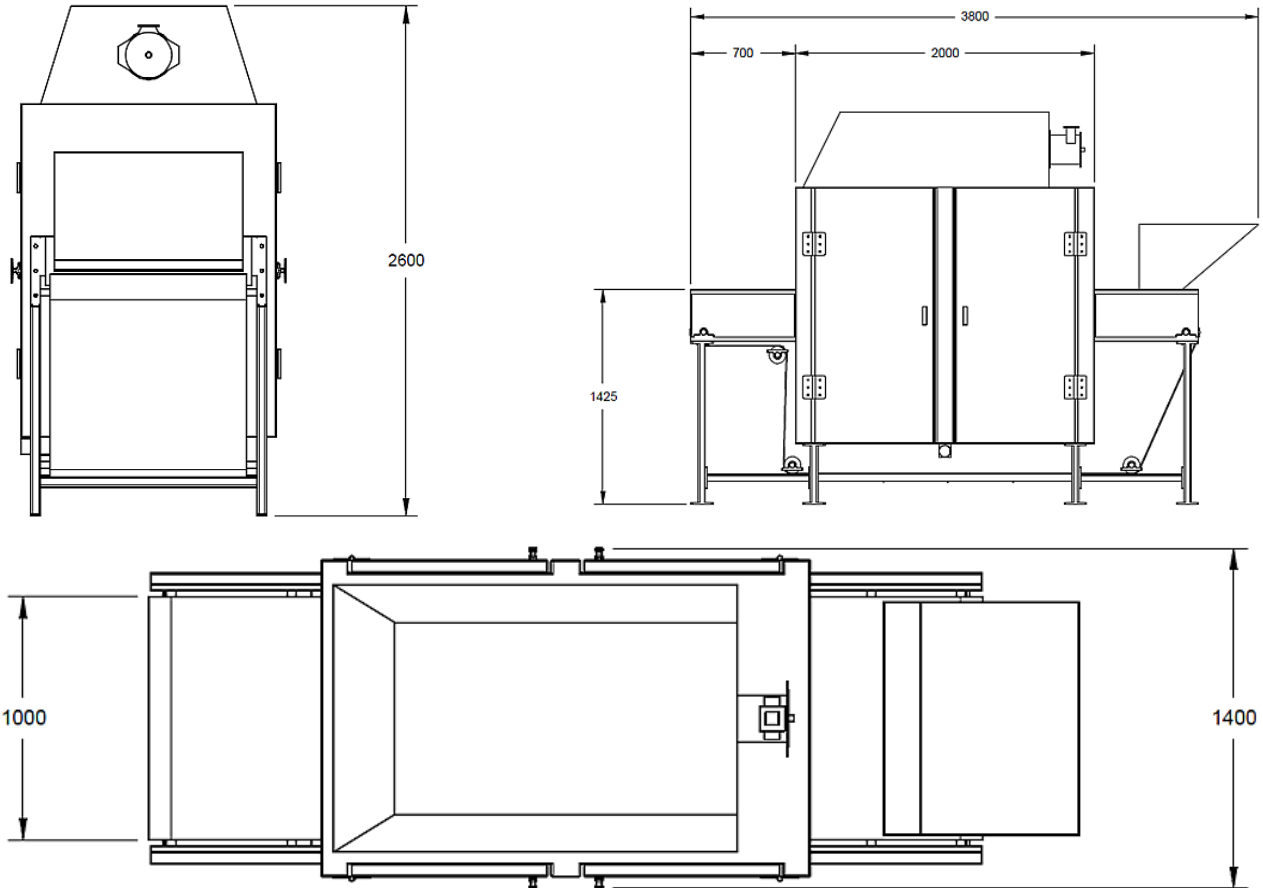

Dimensions



The table below is calculated on a nut roast for a product @ 467ka/m³ with a roast time of 15 minutes.

Bed Depth (mm)	Throughput (Kg/Hr)
25	93
50	187
75	280
100	374
125	467

Additional Information

Specifications	V1000-1H
Bed Depth Range	25mm to 125mm
Residence Time Range	6 minutes to 60 minutes
Heat Capacity Range (typically)*	18kW to 525kW
Steel (Structural Material)	Stainless Steel, 304 & 316 Grade
Belt Width	1000mm Stainless Steel Mesh Belt

* Actual Heat Capacity range is determined and will vary for each client's individual requirements. This is a guide only.