

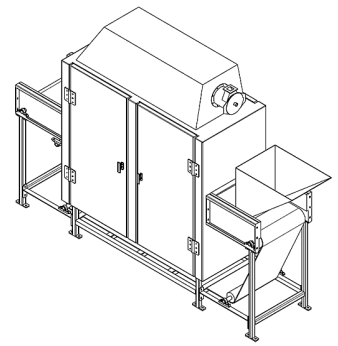

# VESTA V600-1H

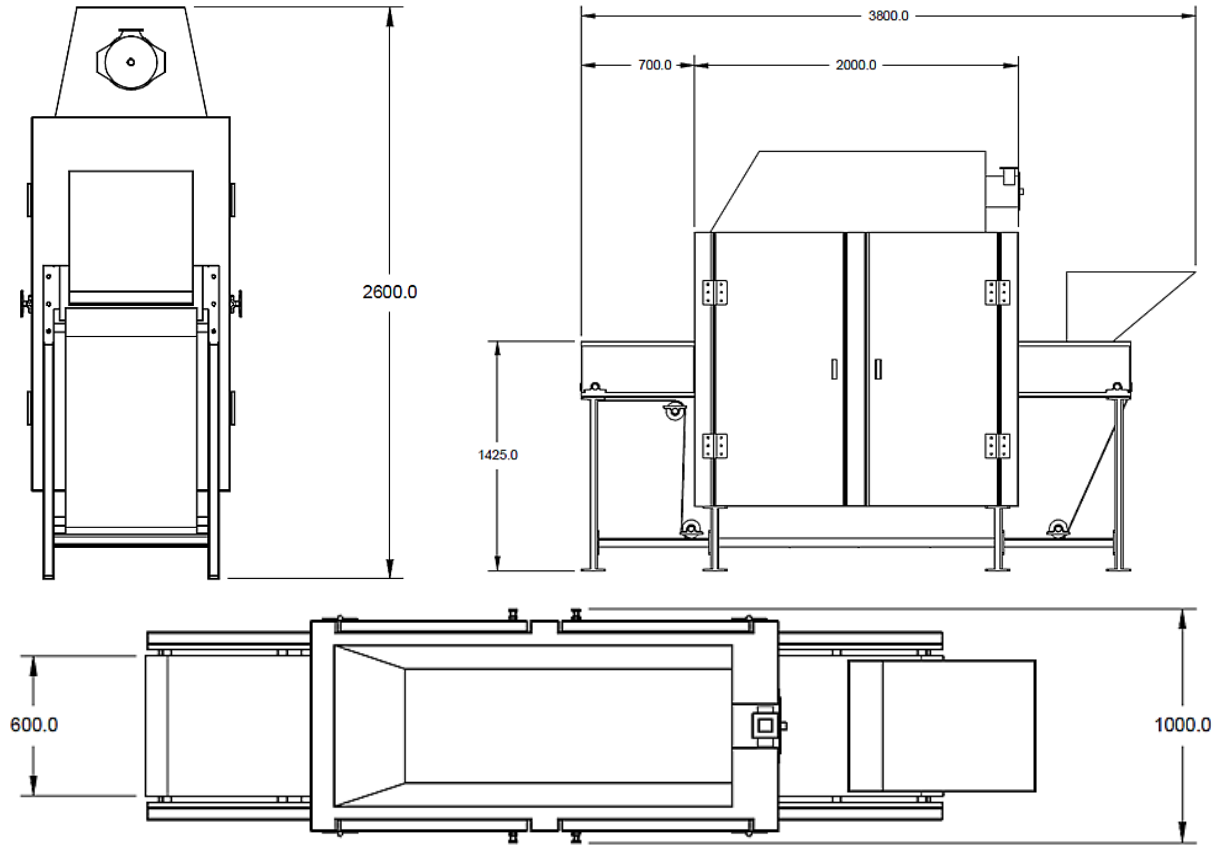

## Dimensions



## Throughput Ranges

The table below is calculated on a nut roast for a product @ 467kg/m<sup>3</sup> with a roast time of 15 minutes.

Bed Depth (mm)	Throughput (Kg/Hr)
25	56
50	113
75	168
100	224
125	280

## Additional Information

Specifications	V600-1H
Bed Depth Range	25mm to 125mm
Residence Time Range	6 minutes to 60 minutes
Heat Capacity Range (typically)*	18kW to 525kW
Steel (Structural Material)	Stainless Steel, 304 & 316 Grade
Belt Width	600mm Stainless Steel Mesh Belt

\* Actual Heat Capacity range is determined and will vary for each client's individual requirements. This is a guide only.